

# MH3022

## Wheel Material Handler



### Engine

Engine Model	Cat® C7.1 ACERT™	
Emissions	EU Stage IV	
Power (Maximum)		
ISO 9249 at 1,550 rpm	126 kW	169 hp
ISO 9249 at 1,550 rpm (metric)		171 hp (PS)
ISO 14396	129.4 kW	174 hp
ISO 14396 (metric)		176 hp (PS)

### Weights

Operating Weight with Worktool	21 500-24 500 kg
--------------------------------	------------------

### Working Ranges

Maximum Reach (stick pin)	11 005 mm
Maximum Height (stick pin)	12 065 mm

### Drive

Maximum Travel Speed	25 km/h
----------------------	---------

## Introduction

*We know that when it comes to material handling equipment, your success depends on high productivity and dependable performance.*

*The MH3022 anchors the smaller end of the new Cat wheel material handlers. It offers a great compromise between the agility, versatility and performance of a wheeled excavator and the stability, efficiency and power needed to cope with harsh environments and applications of industrial, scrap, waste recycling and bulk handling operations, which call for safe, quality and reliable products, while generating a low operating cost to the owner.*

## Contents

Next Generation Key Features .....	4
Sustainability .....	6
Engine .....	7
Built-in Fuel Savers That Add Up .....	7
Hydraulic System .....	8
Structure – Elevated Cab and Frame .....	10
SmartBoom™ .....	12
Front Linkage .....	12
Smart Features .....	13
Load and Go Auto Axle Lock .....	13
Premium Comfort .....	14
Simplicity and Functionality .....	15
Serviceability .....	16
Integrated Technologies .....	17
Work Tool Attachments .....	18
Safety .....	20
Unmatched Visibility .....	22
Complete Customer Care .....	22
Specifications .....	23
Standard Equipment .....	34
Optional Equipment .....	35







The new MH3022 is here to help you take on the wide variety of challenges you face every day, more easily and with more pleasure.

***Commitment from the Ground Up.***





# Next Generation Key Features

Commitment from the Ground Up



### Safety and Comfort Are Not Optional

- Embedded smart devices help enforce safe behaviors, like the automatic swing lock, brake and axle lock, and safety lever
- The new cab contributes to your comfort with limited vibrations and drastically reduced sound levels
- Improved access with new and longer handrails, steps and service platform
- Improved visibility with enlarged glass areas, rear and side cameras and LED working lights



### **Make the Move to the Next Generation**

Refinements. From the whole design to the smallest detail. Convenient features, new advanced and transparent technologies, not only to reduce emissions but to further improve your daily experience when working with our products.

### **Made to be Efficient**

Recognizing that fuel efficiency is directly affected by hydraulic performance, the hydraulic system in the MH3022 is carefully designed to provide the work needed without wasting fuel. A high capacity hydraulic cooling system keeps operating temperatures well-balanced, resulting in longer component life, higher efficiency and lower repair cost.

### **Made to Keep Your Costs Down**

Not only does the machine give you all the performance you need, but it does so while providing a great deal of precision, and speed with an absolute minimum fuel consumption – and zero impact on your efficiency.

### **Maintenance: Keep it Simple**

Ground level and grouped service points, automatic central greasing, dedicated system compartments and many other features that make your maintenance quick and easy.

### **Made to Make Operation Easy and Pleasant**

Have a seat, you will be impressed by the quietness and comfort of the cab. Feel relaxed, we help you make sure you're safe.

### **Integrated Technologies**

Enjoy integrated technologies; they act transparently.

### **Be Flexible to Win**

When you add the multiple Cat attachments that help you do all kinds of jobs, you simply won't find a better machine.







# Sustainability

## Generations Ahead in Every Way

### Fuel Efficiency and Reduced Exhaust Emissions

The engine meets Stage IV emission standards and performs the same amount of work as the previous model, all while burning less fuel, which means more efficiency, less resource consumption, and fewer emissions.

### Quiet Operation

Outstandingly low sound levels, you won't believe your machine is running.

### Transparent Technologies and Longer Service Intervals

- The new Eco Modes, Auto Engine Speed Control and Engine Idle Shutdown help further reduce your overall fuel consumption.
- Product Link™ allows remote monitoring of the machine and helps improve overall efficiency.
- Your Cat dealer can help extend service intervals, meaning fewer fluids and disposals, all adding up to lower costs.

### Biodiesel and Biodegradable Hydraulic Oil

- The MH3022 has the flexibility of running on either ultra-low-sulfur diesel (ULSD) fuel with 10 ppm of sulfur or less or biodiesel (up to B20) fuel blended with ULSD.
- Cat BIO HYDO Advanced HEES™ reduces the impact on the environment.

### Cat Certified Used

This program is a key element in the range of solutions offered by Caterpillar and Cat dealers to help customers achieve growth at the lowest cost while eliminating waste. Used equipment is inspected, guaranteed and ready for work and customers will benefit from a Caterpillar warranty.

# Engine

Power, Reliability, and Fuel Economy



## *The Power and Performance You Need*

### **Constant Power Strategy**

Provides a quick response to changing loads, while delivering the same amount of power regardless of operating conditions.

### **A Transparent Emission Solution That Works.**

The Cat C7.1 ACERT engine meets today's Stage IV emission standards, and it does so without interrupting your job process. It is designed to be:

- **Transparent:** no operator intervention
- **Durable:** fit for life Diesel Particulate Filter (DPF)
- **Efficient:** no work interruption, even in case of extended idling time
- **Simple:** minimum maintenance. Longitudinal engine installation, which further simplifies maintenance

### **Biodiesel Not a Problem**

The engine can run on up to B20 biodiesel fuel that meets ASTM 6751 standards – all to give you more potential fuel-saving flexibility.

### **Proven Technology**

To assure that our technology will meet your expectations for reliable trouble-free service, we subjected these engines and technologies to extensive operating hours of test and validation.

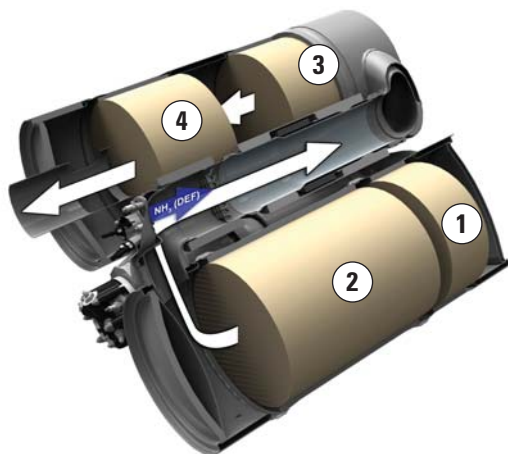

1) Diesel Oxidation Catalyst (DOC) 2) Diesel Particulate Filter (DPF)  
3) Selective Catalytic Reduction (SCR) 4) Ammonia Oxidation Catalyst (AMOX)

## **Built-in Fuel Savers That Add Up**

- Automatic Engine Speed Control: lowers engine speed when it is not needed.
- NEW Engine Idle Shutdown (when activated): turns the engine off when it's been idling for more than a pre-set amount of time.
- NEW Cooling System: variable speed and on-demand fan optimizing consumption.
- NEW enhanced Eco Mode: reduces engine speed while delivering the same power.
- Automatic shift to Travel Mode when you start riding: optimizes driveline performance while preserving fuel.



# Hydraulic System

Fast, Precise, Flexible





***When it comes to moving material quickly, you need efficient hydraulics – the type the MH Series can deliver.***

### **Efficient Design, Smart and Fast**

- **Simple Design** – The new hydraulic valve compartment and routings offer a simple and clean design to help ensure durability. Everything is reachable from ground level.
- **Smart Main Hydraulics** – The system allows reducing the load on the engine when not needed, which translates into lower fuel consumption.
- **Dedicated Swing Pump** – A closed hydraulic circuit is dedicated to the swing only. Having two separate pumps, one for the swing and the second for the other functions allows faster and smoother combined movements.

### **Control Like No Other**

- **Electronic Pump Control** – Controllability is one of the main attributes of the MH3022, and one of the key contributors to this is the Electronic Pump Control (EPC) that's designed to improve response time and precision. It puts flow exactly where you need it, when you need it, which means a much smoother operation and greater efficiency.
- **Adjustable Hydraulic Sensitivity** – Allows you to adjust the aggressiveness of the machine according to the application.
- **Stick Circuit** – Increases efficiency and helps enhance controllability for higher productivity.



### **Well Balanced Cooling Package**

The hydraulic oil cooler is mounted side-by-side with the engine radiator and the air-to-air aftercooler (ATAAC). Located separately from the engine and featuring a well-balanced sizing, the new cooling package offers unprecedented up-times even in difficult environments.

# Structure – Elevated Cab and Frame

Strength, Flexibility and Mobility



## High Visibility – 2400 mm Elevated Cab

The hydraulic cab riser is designed to be:

- Stable – Wide lift arms, deep box-sectioned design, strong top and bottom links and retractable hydraulic cylinders used to raise the cab for greater stability.
- Fast – Two heavy-duty hydraulic cylinders provide quick and controlled up and down travel.
- Comfortable – The parallelogram design of the linkage allows the cab to remain level at all ranges of motion. Cab movement is also slowed as it reaches the end of the riser stroke, with no sudden start/stop effect.
- Safe – The cab can be lowered using either a lever inside the cab or one on the frame at ground level in the event of a hydraulic malfunction.



## Undercarriage Options

Effective hydraulic line routing, transmission protection and heavy-duty axles make the Cat undercarriages perfect for material handler applications. Four different undercarriages are available to provide the stability you need for your applications:

- Material Handling – The Material Handling undercarriage with four welded outriggers is ideal when extra stability is needed.
- Material Handling with Dozer Blade – An optional expansion to the Material Handling Undercarriage includes an additional dozer blade mounted ahead of the front stabilizers to be used to push material commonly encountered in waste and millyard applications.
- The Material Handling Narrow undercarriage, specifically designed for limited space applications – Thanks to smaller undercarriage width and length, compared to MH undercarriage, and thanks to its symmetrical design, this MH Narrow undercarriage enhances maneuverability and flexibility in tight areas.
- The standard undercarriage allows for different kinds of stabilizers and blades to be attached either to the front or to the rear.

## Heavy-Duty Axles

The front axle offers wide oscillating and steering angles. The transmission is mounted directly on the rear axle for protection and optimum ground clearance.

## Advanced Disc Brake System

The disc brake system acts directly on the hub instead of the drive shaft to avoid planetary gear backlash. This minimizes the rocking effect associated with working free on wheels.

## Driveline Concept

The driveline design effectively utilizes engine torque and power to provide a comfortable ride with improved smoothness.

## Ground Clearance

The MH3022 offers good ground clearance, with the transmission mounted and protected by the rear axle.





## Front Linkage

### Durability – Built with No Compromises

You know that a material handler works only as good as its front linkage is able to handle the job. The MH3022's booms and sticks are purpose built for the loads encountered in material handling applications.

#### MH Boom

MH booms include high pressure hydraulic lines for opening and closing functionality and medium pressure lines for implement rotation. A short MH boom is available to match indoor applications while retaining the same performance and lifting capabilities.

#### MH Sticks

MH sticks are equipped with high and medium pressure auxiliary lines. The 4900 mm Drop Nose Stick offers the reaching and lifting capabilities required for typical MH applications, while the 4200 mm Straight Stick is the best solution when additional work tool functionality is needed.

#### Special Applications

The MH3022 offers the ability to combine the hydraulic cab riser with a traditional excavator front linkage. This combination has been proven in transfer station, mining, and millyard applications.

Automatic lubrication of the whole uppercarriage extends component life, protecting your equipment.

## SmartBoom

### Allow Your Operator to Fully Concentrate on Production

The unique Cat SmartBoom significantly enhances operator comfort and job efficiency by reducing stress and vibrations transmitted to the machine. Loading is more productive and more fuel efficient as the return cycle is reduced while the boom down function does not require pump flow.

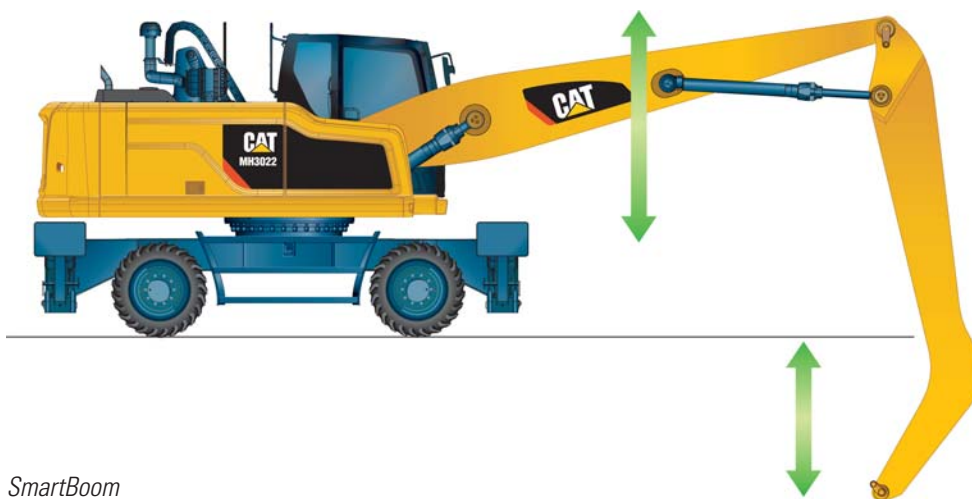

*SmartBoom*



# Smart Features

When Operation Becomes as Easy as Pleasant

## Joystick Steering (Optional)

Keep both hands on your joysticks even when you need to reposition the machine while simultaneously moving the implements.

## Swing and Auto Travel Lock

No need for the operator to bend to engage the swing lock pin.

- Just press a button,
- Align the upper to the lower frame,
- Enjoy the ride: a green indicator confirms the swing and the implements have been automatically locked.

## Integrated Pin Code

No need to buy optional security system to protect your equipment against theft.

- The pin code is integrated into the monitor (standard)
- Entering the right code allows the engine to start

The Machine Security System (MSS – optional) adds even more protection when needed.

## Cruise Control

Focus on the working environment, not on your foot. No need to press the pedal all the time.

- Choose the very speed you wish
- Press the quick access button on the monitor
- Enjoy the ride



## Load and Go Auto Axle Lock Presses the Pedal for You, Reducing the Number of Actions You Need to Do

The machine automatically detects when the service brake and axle need to be locked (like when working), or unlocked (roading), hence removing the need for the operator to systematically press the pedal. Brake and axle are released automatically by pressing the travel pedal again.



# Premium Comfort

Keeps Operators Productive All Shift Long



## Legacy from the Renowned Cat Wheel Material Handlers

Designed for the operator, our cabs are unique.

## Ergonomic Layout

- Frequently used switches are centralized, kept to the minimum and ideally located close to the joysticks.
- Storage compartments are useful ... when well designed. The lunch box provides sufficient room to store a hard hat. Several other areas include drink, phone, or key holders.

## Comfortable Seat Options

Our seats provide all the comfort needed for a long day of work, including FULL adjustment. All seats are heated and air suspended. Automatic weight adjustment and air cooled seats are available.

## Safety – Not Optional

FOPS cabs, seat belt alarm, safety lever, sideview camera ... among others.

## Details That Make the Difference

Have a look at the cab; you will see it is through details that we improve pleasure of operating.

## Smart Controls to Reduce Fatigue

- Features like SmartBoom or joystick steering will be precious to increase your productivity.
- New technologies that work transparently like the swing and auto travel lock or the automatic brake and axle lock, reduce the number of tasks you need to do.

## Plug, Charge and Play Your Devices

- The 12V 10A power supply socket is conveniently located for charging your laptop, or a tablet.
- A CD/MP3 radio with speakers and USB port is available.







# Simplicity and Functionality

## For Ease of Operation

### A Cab Just for You – Fully Adjustable

- Seat armrests, in height and angle
- Steering column adjustment, not only tilting fore/aft but also in height
- Hydraulic sensitivity of the machine to make it more or less aggressive
- Joystick controls, buttons and thumb wheels
- Automatic air conditioning

### Incredibly Low Sound Levels, Less Fatigue

Operator sound level has been reduced thanks to a new cab design and increased cab pressure, which also prevents from dust entry. Add in the rubber mounts to fix the cab on the frame and you have a cab that's as quiet as any of today's premium cars.

### Outstanding Visibility: See the difference!

- Standard LED working lights and halogen roading lights
- Standard LED dome light
- All glass areas have been drastically increased
- Choice of 70/30 front windshield or one piece windshield
- New wide angle mirrors including a lower mirror for a better visibility to the ground
- Parallel intermittent (four speeds) wipers covering the whole windshield



### Standard Rear and Side Wide Angle Cameras

Cameras let you see what's going on around. The image from the side camera is displayed on an additional wide color screen, offering the full view from the front to the rear of the machine. The rear camera is integrated into the counterweight for enhanced protection.

### Large Color Monitor

Easy to read and in local language, the high resolution LCD monitor will keep you aware of any important information. "Quick Access" buttons allow a quick selection of favorite functions. The tool select function lets you preset up to ten different hydraulic attachments for quick tool changes.

# Serviceability

## When Uptime Counts

### Convenient Access Built In

You can reach routine maintenance items like fuel and engine oil filters and fluid taps at ground level while fuel and DEF tank accessible from the safety of the slip-resistant new service foldable step. Compartments feature wide composite service doors, designed to be more resistant to shocks, which all include gas struts to facilitate the opening. Components are now gathered in specific dedicated compartment, like the special electrical compartment.

### A Smart Design for Any Temperature

The side-by-side and axial fan design allows greater cooling performance. The system is completely separated from the engine compartment to reduce noise and heat, and all radiators are gathered in the same compartment while featuring easy-to-clean cores with a tilting device that requires no tool to unlock.

### A Fresh Idea

Ventilation inside the cab allows outside air to enter through a fresh air filter. The filter is located on the side of the cab to make it easy to reach, and it is protected by a lockable door that can be opened with the ignition key.

### Lube and Fuel Options

An automatic lubricator system is an available time-saving standard feature for greasing the whole uppercarriage. Greasing points for the undercarriage are kept to a minimum and grouped. An electric refueling pump is also available. The hose is stored in a dedicated tray, for more cleanliness. Add in the new electric lift pump removing the need to prime the system manually, the standard fuel and water separator and you get a machine that does the fastidious works for you.

***Keep it simple.***





# Integrated Technologies

## It Pays to Know



Cat Connect makes smart use of technology and services to improve your job site efficiency. Using the data from technology-equipped machines, you'll get more information and insight into your equipment and operations than ever before.

Cat Connect technologies offer improvements in these key areas:



**Equipment Management** – increase uptime and reduce operating costs.



**Productivity** – monitor production and manage job site efficiency.



**Safety** – enhance job site awareness to keep your people and equipment safe.

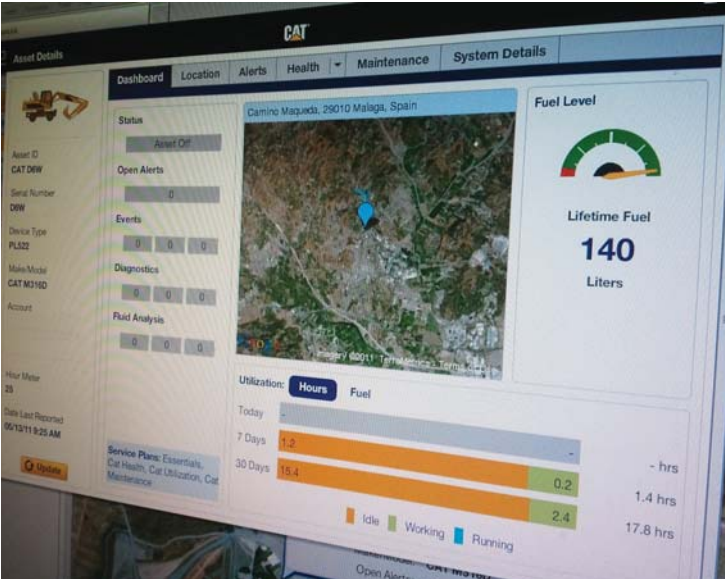

Featured Cat Connect technologies include the following:

### Link

Link technologies provide wireless capability to machines to enable two-way transfer of information collected by on-board sensors, control modules, and other Cat Connect technologies.

### Manage Your Machine Remotely

Cat Product Link is a system that is deeply integrated into the machine monitoring system to take the guesswork out of managing your equipment. The system tracks location, hours, fuel usage, productivity, idle time, and diagnostic codes and shares it with you through VisionLink® to help you maximize efficiency, improve productivity, and lower operating costs.

# CAT® CONNECT



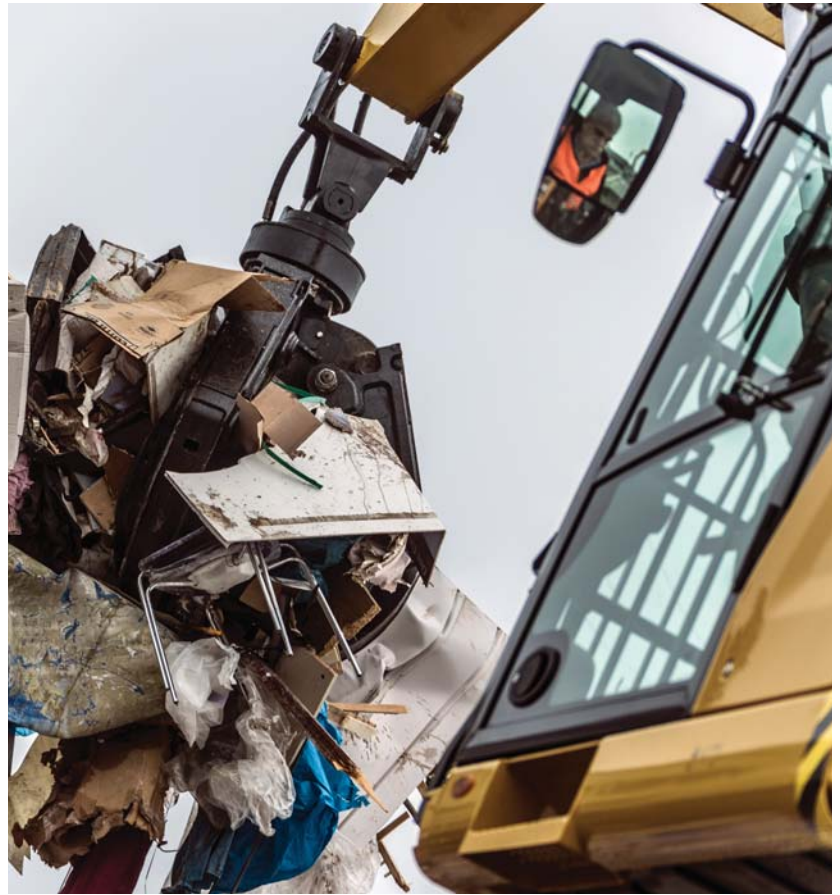

## Work Tool Attachments

Move More, Make More



### Power Match\*

Match your Cat hydraulic work tools to your Cat machine, and get the most out of the standard, built-in software. Ten hydraulic pump flow and pressure settings can be preset within the monitor, eliminating the need to adjust the hydraulics each time a tool is changed. Attachment changes have never been easier!

\*For straight/linkage sticks.





## Attachment Solutions for Scrap Recycling, Bulk Handling

When productivity, reliability and stability are important, Cat attachments are the perfect solution for the MH3024. Choose one for your Cat machine for maximum performance.

### Productive and Perfectly Matched

Loading and unloading is foundational to your productivity. Grapples are sized right for the MH3024. They are designed for maximum penetration into the pile. The full power of your machine is utilized to provide fast open/close times and powerful closing force. Full, 360° rotation systems allow precise placement. Together, an MH3024 and Cat grapple allow you to move volumes with minimal time and effort.

### Built for Severe Material

Cat grapples are built to take on the material you move. Hydraulic components are protected from damage, yet easily accessed for routine maintenance. Areas that dig and penetrate are made of high quality, wear resistant material to keep them in working condition. Components that pivot and move are engineered to the latest standards for a long life. Cat grapples last for a positive impact to your bottom line.



### Orange Peel Grapples

The perfect solution for scrap yards, recycling plants and transfer stations. These grapples are available with 4 or 5 tines, in capacities from 600 to 1000 L. Several shell choices allow further customization of your grapple to the specific material you work with.



### Clamshell Grapples

The perfect solution for loading and transferring large volumes of loose material like grain, coal, sand and gravel. These grapples are configured with several shells for different capacity options to meet your specific requirements.



### Digging Grapples

Cat Digging grapples are designed to suit MH machines for digging applications where good penetration is required.

### Waste Handling Grapples

The dedicated waste handling grapple has been specifically designed to offer high volume for maximum loads and proven fuel consumption.



Contact your local Cat dealer to learn more about the specific grapple choices available in your region.

# Safety

Your Safety Is NOT Optional

## Embedded Features

Smart devices are embedded to offer as much safety as possible for your operators and help enforce safe behavior:

- Safety seat belt and warning indicators (monitor)
- Automatic swing lock
- Automatic brake and axle lock
- Safety lever, preventing exit when the implements are not locked out
- Emergency shut off switch and battery switch disconnect
- Adjustable travel alarm
- Lowering check valves

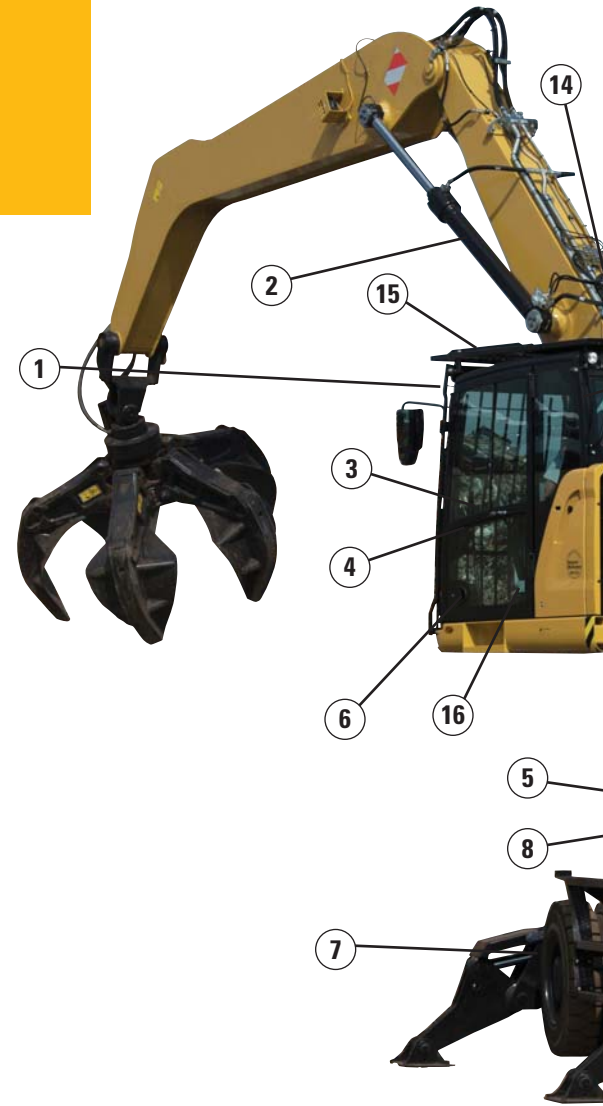

## Cab Ingress

We bring a solution to allow you to safely climb into the cab:

- Three longer access steps, aligned with the cab entry
- New additional step integrated into the skirt, directly below the cab door
- Anti-skid plates on all walkways and steps reducing slipping hazards
- Convenient door handrail
- Additional extended handrail, from the top to the bottom of the cab
- Tiltable console, not to obstruct entry into the cab
- Safety lever built into the tiltable console to make sure the way in and out is free of obstacles



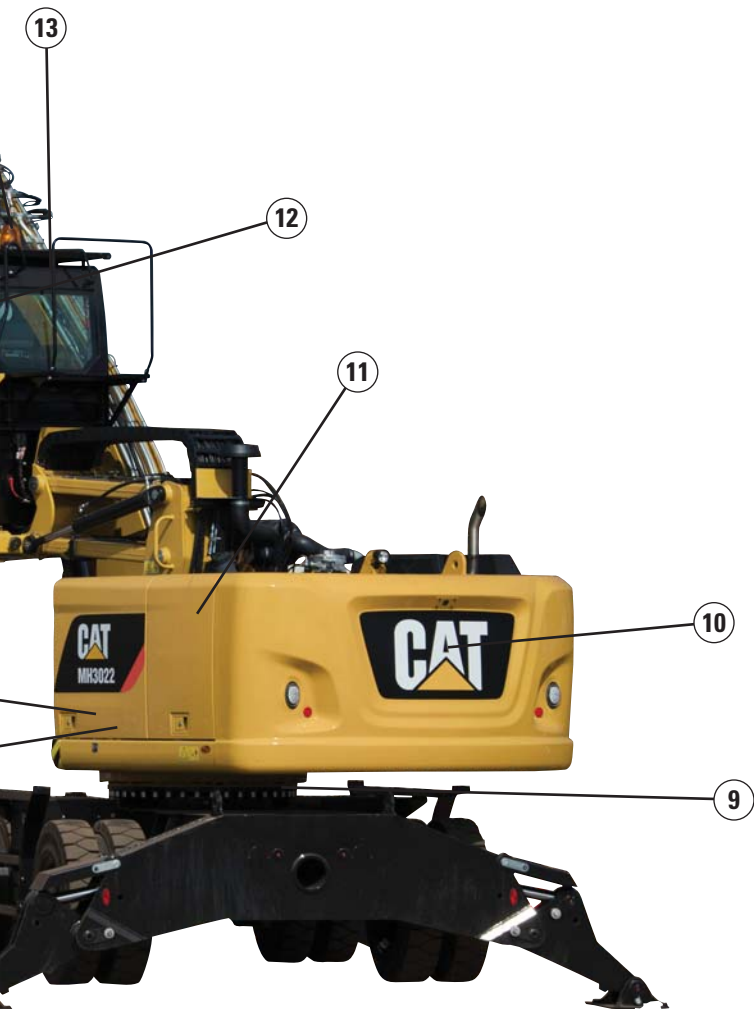

- 1) Laminated windshield and skylight window
- 2) Lowering check valves
- 3) Safety seat belt indicator
- 4) Safety lever
- 5) Emergency shut-off switch
- 6) Automatic brake and axle lock
- 7) Punched, anti-slippery walking surfaces
- 8) Battery switch disconnect
- 9) Swing and implement electronic lock
- 10) Adjustable travel alarm
- 11) All doors equipped with gas spring cylinders
- 12) Emergency hammer and exit
- 13) Sound proofing
- 14) Beacon available
- 15) FOPS cab and top/front guards compatibility
- 16) Safety lever to lower the cab, either from the ground or directly from the cab

### Smart Lighting

- LED lights for all working lights for enhanced visibility
- Halogen lights for all roading lights
- LED dome light for better illumination inside the cab



### Safe and Quiet Cab

The all-new cab provides you with a safe environment. It also contributes to your comfort with limited vibrations and drastically reduced sound levels.

### Great Views

- Enlarged glass gives you excellent visibility to the front, top, rear, and sides, even to the right
- Standard rearview camera gives you a clear field of view behind the machine through the monitor. Camera is integrated into the counterweight.
- Standard sideview camera, to check nothing is hidden to you from the front right hand side to the rear of the machine
- Lenses of all the cameras are wide angle and heated
- All mirrors are wide angle and allow view not only around the machine but also to the ground

# Unmatched Visibility

Make Sure Nothing Is Hidden to You

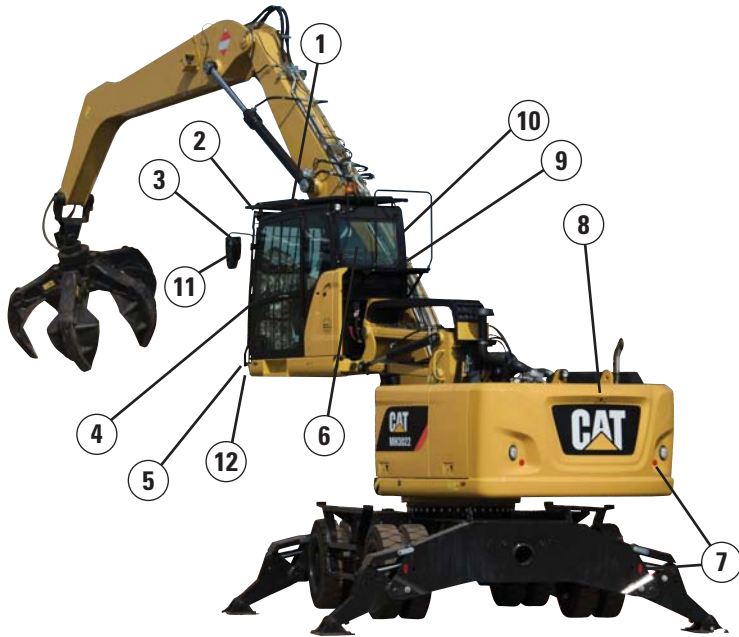

**Visibility all around is critical**, especially for machines working and driving on industrial job sites.

- 1) Increased skylight and windshield glass area
- 2) Improved lighting with standard LED lights for all working lights
- 3) Optional heated mirrors
- 4) Great left hand side visibility with the new all glass door
- 5) Halogen roading lights
- 6) Wide rear window
- 7) Reflecting red lights on rear and blade/outriggers
- 8) Standard wide rearview camera
- 9) Standard side camera and dedicated wide monitor
- 10) Large right hand side window
- 11) Mirrors, wide angle, with additional lower mirror for ground visibility
- 12) High visibility – 2400 mm elevated cab

## Complete Customer Care

Your Cat Dealer Will Support You Like No Other

### Support You Can Count On

From helping you to choose the right machine to knowledgeable on-going support, Cat dealers provide the best-in-sales and services.

- **Best long-term investment** with financing options and services
- **Productive operation** with training programs
- **Preventive maintenance** and guaranteed maintenance contracts
- **Uptime**, with best-in-class parts availability
- **Repair, rebuild, or replace?** Your dealer can help evaluate the best option.

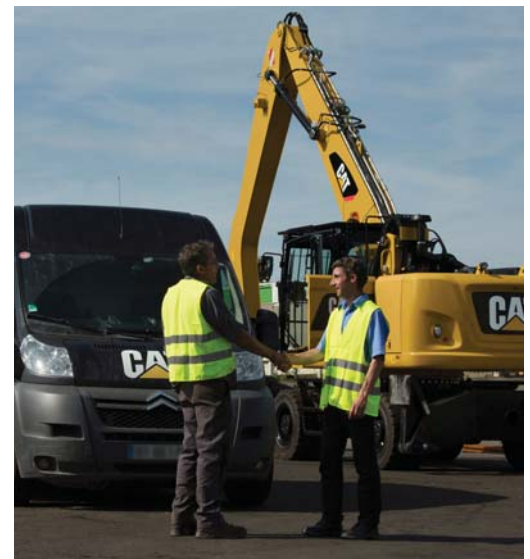



# MH3022 Wheel Material Handler Specifications

Engine		
Engine Model	Cat C7.1 ACERT <sup>(1)</sup>	
Ratings	1,550 rpm	
Engine Power (Maximum)		
ISO 14396	129.4 kW	174 hp
ISO 14396 (metric)	176 hp (PS)	
Net Power (Rated) <sup>(2)</sup>		
ISO 9249	126 kW	169 hp
ISO 9249 (metric)	171 hp (PS)	
80/1269/EEC	126 kW	169 hp
Net Power (Maximum)		
ISO 9249	126 kW	169 hp
ISO 9249 (metric)	171 hp (PS)	
80/1269/EEC	126 kW	
Bore	105 mm	
Stroke	135 mm	
Displacement	7.01 L	
Maximum Torque at 1,400 rpm	830 N·m	
Number of Cylinders	6	

<sup>(1)</sup> Meets Stage IV emission standards.

<sup>(2)</sup> Rated speed 1,550 rpm. Constant power from 1,500-1,550 rpm.

- Net power advertised is the power available at the flywheel when engine is equipped with air cleaner, CEM exhaust gas aftertreatment, alternator, and cooling fan running at intermediate speed.
- No deratings required up to 3000 m altitude. Automatic derating occurs after 3000 m.

Transmission	
Forward/Reverse	
1st Gear	10.0 km/h
2nd Gear	25.0 km/h
Creeper Speed	
1st Gear	3.0 km/h
2nd Gear	10.0 km/h
Drawbar Pull	127.0 kN
Maximum Gradeability	68%

Swing Mechanism	
Swing Speed	8.5 rpm
Swing Torque	48.0 kN·m

Undercarriage*	
Maximum Steering Angle	35.0°
Oscillation Axle Angle	±5.0°
Minimum Turning Radius	
Outside of Tire	6800 mm
End of VA Boom	7800 mm
End of One-Piece Boom	9300 mm

\*Dimensions valid for standard undercarriage.

Service Refill Capacities	
Fuel Tank (total capacity)	330 L
Diesel Exhaust Fluid Tank	34.5 L
Cooling System	46.9 L
Engine Crankcase	18.5 L
Rear Axle Housing (differential)	14 L
Front Steering Axle (differential)	10.5 L
Final Drive	2.5 L
Powershift Transmission	2.5 L

# MH3022 Wheel Material Handler Specifications

## Weights

Operating Weights*	21 500-24 500 kg
Long MH Boom (6.4 m)	
MH Undercarriage, Straight Stick	23 670 kg
MH Undercarriage, Drop Nose Stick	23 250 kg
MH Narrow Undercarriage, Drop Nose Stick	22 340 kg
Standard Undercarriage**, Straight Stick	22 730 kg
Short MH Boom (5.35 m)	
Narrow Undercarriage, Straight Stick	22 540 kg
One-Piece Boom	
Standard Undercarriage**, Industrial Stick	21 650 kg
VA Boom	
Standard Undercarriage**, 2800 mm Stick	22 630 kg
Sticks***	
Digging (2800 mm)	970 kg
Straight (4200 mm)	1265 kg
Drop Nose (4900 mm)	860 kg
Industrial (3300 mm)	500 kg
MH Push Blade	675 kg
Dozer Blade	850 kg
Solid Tires (delta vs. standard tires)	950 kg
Counterweight	
Standard	3700 kg
Optional	4200 kg

\*Operating weight includes solid tires, 3700 kg counterweight, full fuel tank, operator, four outriggers undercarriage, attachment (1400 kg). Weight varies depending on configuration.

\*\*Standard undercarriage with 2 sets of outriggers and dual pneumatic tires.

\*\*\*Includes cylinder, bucket linkage, pins and standard hydraulic lines.

## Hydraulic System

Tank Capacity	153 L
System	345 L

## Hydraulic System: Maximum Pressure

Implement Circuit	
Normal	350 bar
Heavy Lift	370 bar
Travel Circuit	350 bar
Auxiliary Circuit	
High Pressure	350 bar
Medium Pressure	210 bar
Swing Mechanism	310 bar

## Hydraulic System: Maximum Flow

Implement/Travel Circuit	288 L/min
Auxiliary Circuit	
High Pressure	250 L/min
Medium Pressure	49 L/min
Swing Mechanism	108 L/min

## Tires

10.00-20 (dual pneumatic)\*

11.00-20 (dual pneumatic)\*\*

10.00-20 (dual solid rubber)

\*Not compatible with MH undercarriage.

\*\*Not compatible with MH Narrow undercarriage.

## Push Blade

Blade Type	Radial
Blade Height	920 mm
Width	2990 mm



# MH3022 Wheel Material Handler Specifications

## Emissions and Safety

Engine Emissions	Stage IV
Diesel Exhaust Fluid	Must meet ISO 22241
Fluids (Optional)	
Cat Bio HYDO™ Advanced	Readily biodegradable EU Flower eco-label certified
Biodiesel up to B20	Meets EN 14214 or ASTM D6751 with EN590 or ASTM D975 standard mineral diesel fuels
Vibration Levels	
Maximum Hand/Arm	
ISO 5349:2001	<2.5 m/s <sup>2</sup>
Maximum Whole Body	
ISO/TR 25398:2006	<0.5 m/s <sup>2</sup>
Seat Transmissibility Factor	
ISO 7096:2000-spectral class EM5	<0.7

## Standards

Operator Protective Structure	
Top/Front Guards	FOPS (Falling Object Protective Structure) meets FOPS criteria ISO 10262:1998 and SAE J1356:2008
Cab/Sound Levels	Meets appropriate standards as listed below

## Sound Performance

Operator Sound	
2000/14/EC	71 dB(A)
Spectator Sound	
2000/14/EC	100 dB(A)

- Operator Sound – The operator sound level is measured according to the procedures specified in 2000/14/EC, for a cab offered by Caterpillar, when properly installed and maintained and tested with the door and windows closed.
- Exterior Sound – The labeled spectator sound power level is measured according to the test procedures and conditions specified in 2000/14/EC.
- Hearing protection may be needed when operating with an open operator station and cab (when not properly maintained for doors/windows open) for extended periods or in noisy environment(s).

# MH3022 Wheel Material Handler Specifications

## Dimensions – With Standard Undercarriage\*

All dimensions are approximate.

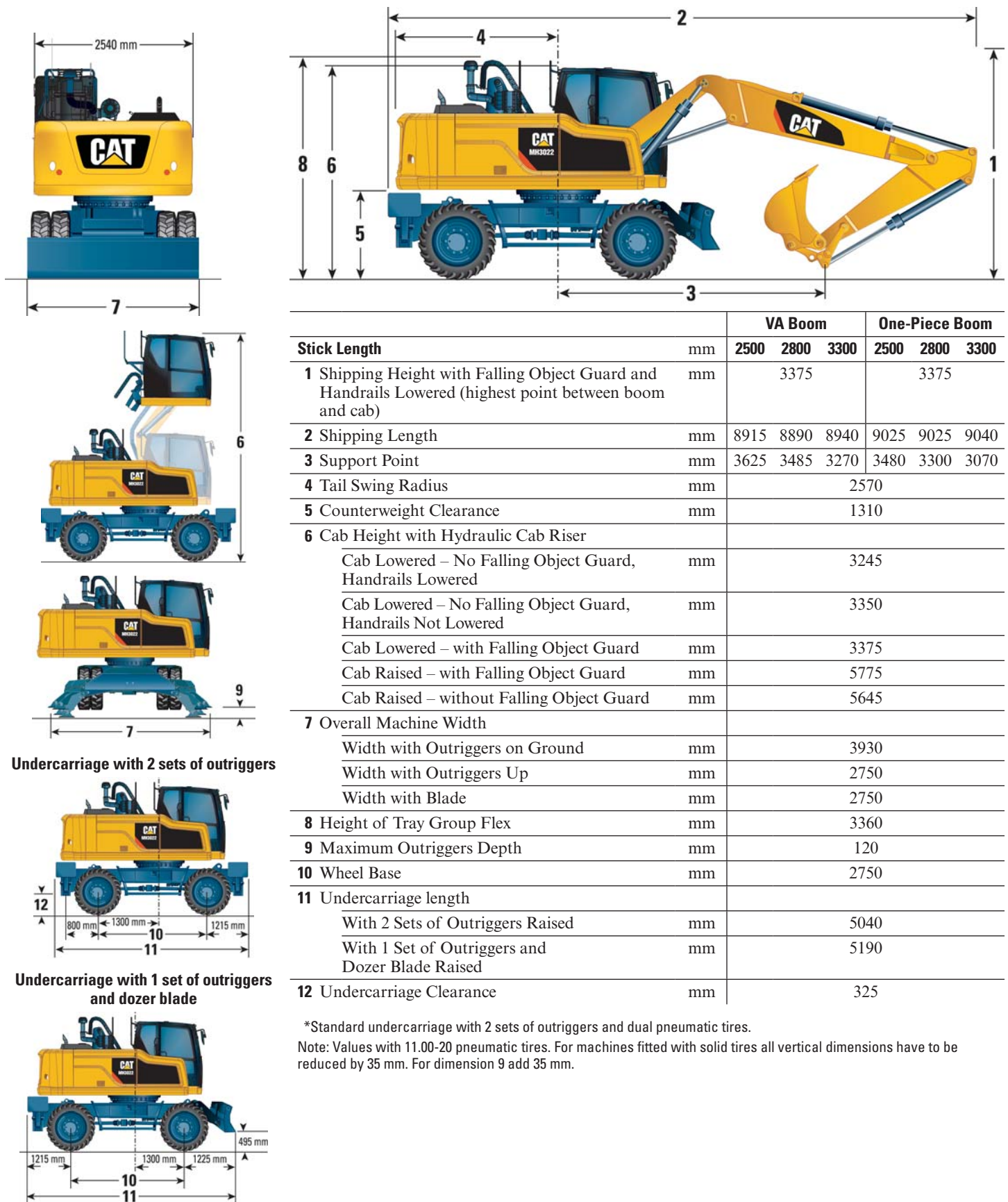

Stick Length	mm	VA Boom			One-Piece Boom		
		2500	2800	3300	2500	2800	3300
1 Shipping Height with Falling Object Guard and Handrails Lowered (highest point between boom and cab)	mm	3375			3375		
2 Shipping Length	mm	8915	8890	8940	9025	9025	9040
3 Support Point	mm	3625	3485	3270	3480	3300	3070
4 Tail Swing Radius	mm	2570					
5 Counterweight Clearance	mm	1310					
6 Cab Height with Hydraulic Cab Riser							
Cab Lowered – No Falling Object Guard, Handrails Lowered	mm	3245					
Cab Lowered – No Falling Object Guard, Handrails Not Lowered	mm	3350					
Cab Lowered – with Falling Object Guard	mm	3375					
Cab Raised – with Falling Object Guard	mm	5775					
Cab Raised – without Falling Object Guard	mm	5645					
7 Overall Machine Width							
Width with Outriggers on Ground	mm	3930					
Width with Outriggers Up	mm	2750					
Width with Blade	mm	2750					
8 Height of Tray Group Flex	mm	3360					
9 Maximum Outriggers Depth	mm	120					
10 Wheel Base	mm	2750					
11 Undercarriage length							
With 2 Sets of Outriggers Raised	mm	5040					
With 1 Set of Outriggers and Dozer Blade Raised	mm	5190					
12 Undercarriage Clearance	mm	325					

\*Standard undercarriage with 2 sets of outriggers and dual pneumatic tires.

Note: Values with 11.00-20 pneumatic tires. For machines fitted with solid tires all vertical dimensions have to be reduced by 35 mm. For dimension 9 add 35 mm.



# MH3022 Wheel Material Handler Specifications

## Dimensions – With MH and MH Narrow Undercarriage

All dimensions are approximate.

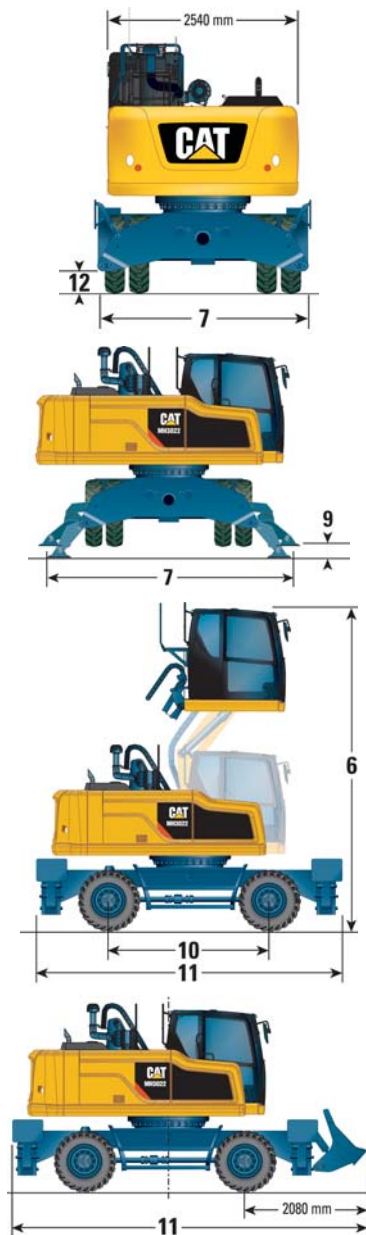
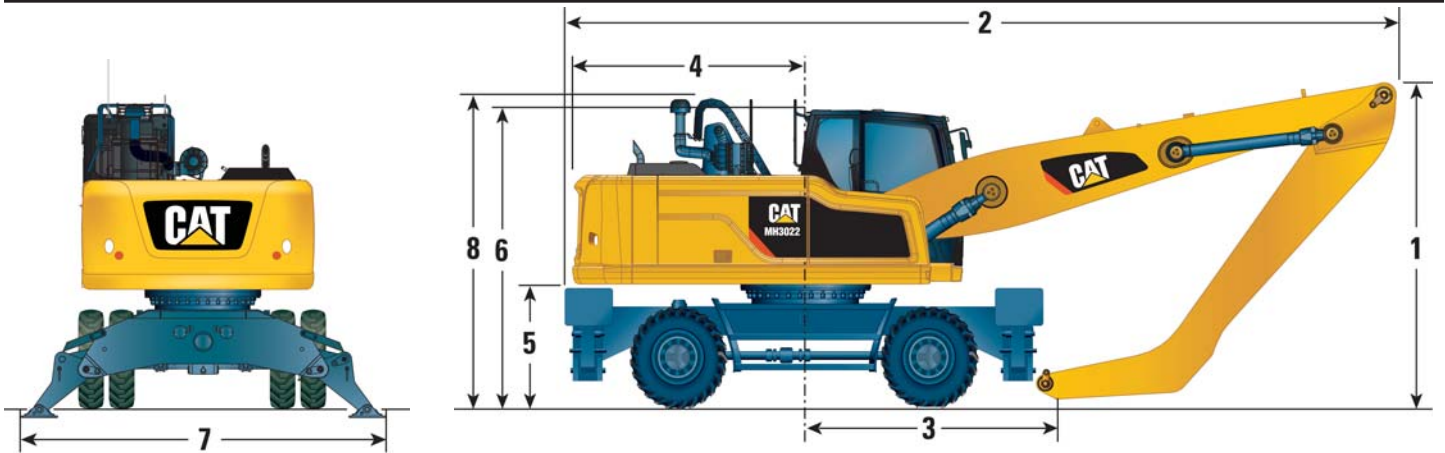

		MH Undercarriage		MH Narrow UC*	
		Long MH Boom	Drop Nose	Short MH Boom	Drop Nose
<b>Boom Length</b>	mm	<b>6400</b>		<b>5350</b>	
<b>Stick Type</b>		<b>Straight</b>	<b>Drop Nose</b>	<b>Straight</b>	<b>Drop Nose</b>
<b>Stick Length</b>	mm	<b>4200</b>	<b>4900</b>	<b>4200</b>	<b>4900</b>
<b>1 Shipping Height with Falling Object Guard and Handrails Lowered (highest point between boom and cab)</b>	mm	3340	3620	3340	4535
<b>2 Shipping Length</b>	mm	9420	9280	8310	7885
<b>3 Support Point</b>	mm	3230	2760	2190	2180
<b>4 Tail Swing Radius</b>	mm	2570			
<b>5 Counterweight Clearance</b>	mm	1275			
<b>6 Cab Height with Hydraulic Cab Riser</b>					
Cab Lowered – No Falling Object Guard, Handrails Lowered	mm	3210			
Cab Lowered – No Falling Object Guard, Handrails Not Lowered	mm	3315			
Cab Lowered – with Falling Object Guard	mm	3340			
Cab Raised – with Falling Object Guard	mm	5740			
Cab Raised – No Falling Object Guard	mm	5610			
<b>7 Overall Machine Width</b>					
Width with Outriggers on Ground	mm	4360		3680	
Width with Outriggers Up	mm	2990		2550	
Width with the Special Front Push Blade	mm	2990		NA	
<b>8 Height of Tray Group Flex</b>	mm	3325			
<b>9 Maximum Outriggers Depth</b>	mm	90		120	
<b>10 Wheel Base</b>	mm	2750		2600	
<b>11 Undercarriage Length</b>	mm	5250		4900	
With MH Undercarriage Front Push Blade	mm	6080		NA	
<b>12 Undercarriage Clearance</b>	mm	245		295	

\*Dimensions with MH Narrow undercarriage, outriggers front and rear, and without work tool.

When the shipping height is over 4 m, the stick must be removed for transportation.

Note: Values are with 10.00-20 pneumatic or with solid tires. For machine fitted with 11.00-20 pneumatic tires and MH Undercarriage all vertical dimensions have to be increased by 35 mm. For dimension 9 reduce by 35 mm.

# MH3022 Wheel Material Handler Specifications

## Working Ranges

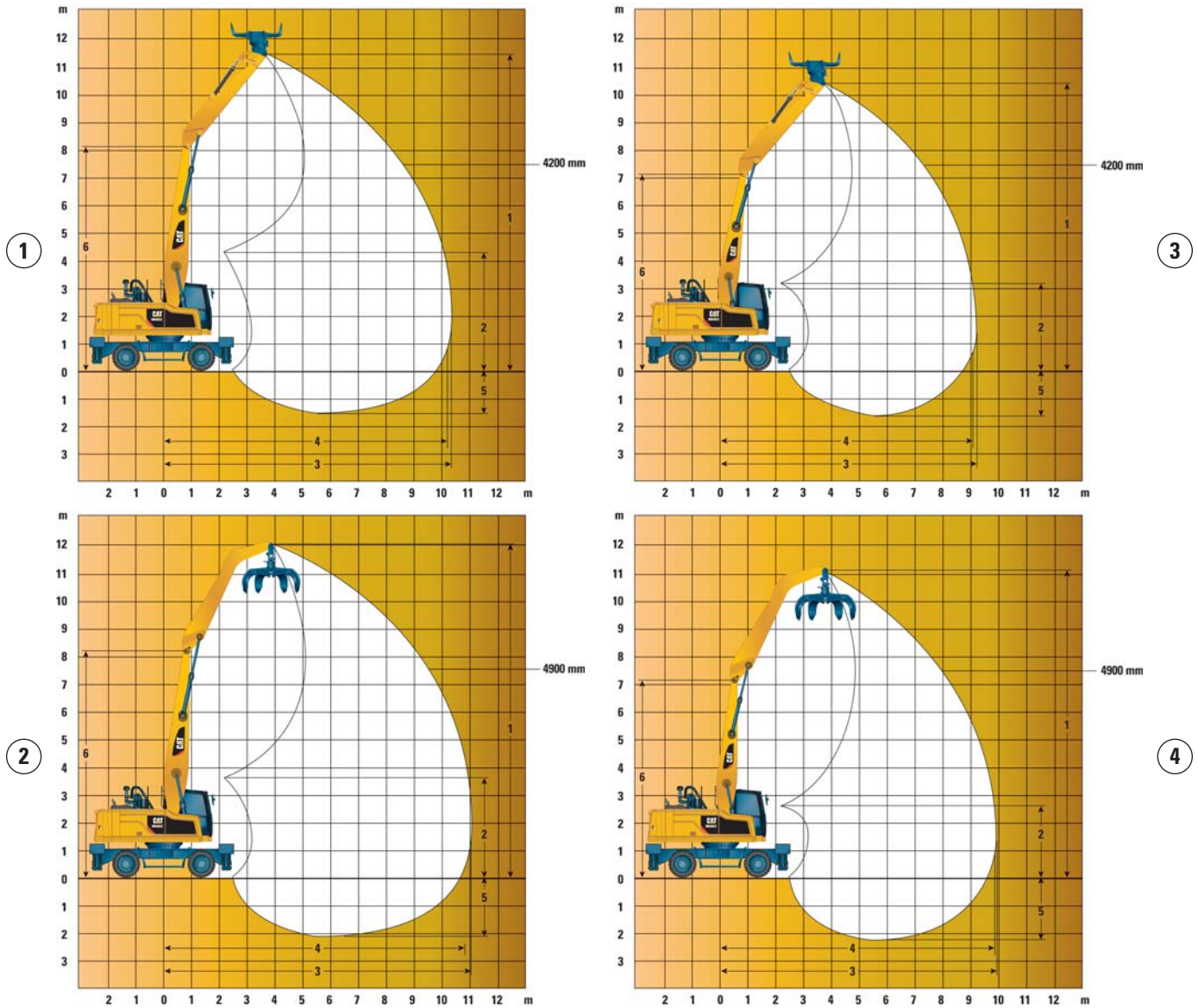

		MH3022			
		①	②	③	④
		MH Boom		Short MH Boom	
<b>Boom Type</b>		MH Boom		Short MH Boom	
<b>Boom Length</b>	mm	6400		5350	
<b>Stick Length</b>	mm	4200	4900	4200	4900
<b>1 Maximum Height</b>	mm	11 520	12 065	10 445	11 020
<b>2 Minimum Dump Height</b>	mm	4330	3680	3255	2635
<b>3 Maximum Reach</b>	mm	10 345	11 005	9325	9990
<b>4 Maximum Reach at Ground Level</b>	mm	10 175	10 845	9145	9815
<b>5 Maximum Depth</b>	mm	1485	2185	1655	2325
<b>6 Boom Pin Height</b>	mm	8235		7160	

All dimensions refer to sticknose pin, with solid tires.

These dimensions are independent from the undercarriage type (whether it is MH or MH Narrow undercarriage).



# MH3022 Wheel Material Handler Specifications

## MH3022 Work Tool Offering Guide with Straight Sticks\*

Boom Length		One-Piece Boom				MH Boom (6.4 m)		MH Boom (5.35 m)	
Counterweight		3700 kg		4200 kg		3700 kg	4200 kg	3700 kg	4200 kg
Undercarriage/Outriggers		(1)		(1)		(1)	(1)	(1)	(1)
Stick Length		2500 mm	2800 mm	2500 mm	2800 mm	4200 mm	4200 mm	4200 mm	4200 mm
Stick Type		Straight	Straight	Straight	Straight	Straight	Straight	Straight	Straight
Hydraulic Hammer	H115Es								
	H120Es								
	H130Es								
Multi-Processor	MP318 CC Jaw								
	MP318 D Jaw								
	MP318 P Jaw								
	MP318 U Jaw								
	MP318 S Jaw								
Crusher	P315								
Pulverizer	P215								
Sorting Grapple	G315 GC								
	G315B WH								
	G315B-D/R								
Scrap Shear	S320B								
	S325B								
Compactor Plate	CVP75								
Pin Grabber Coupler	CL-QC	These couplers are available for the MH3022 (with straight stick and linkage).							
Dedicated Quick Coupler	CW-30								
	CW-30S								

(1) MH undercarriage with 2 sets outriggers

Work tool is a match
  Pin-on or dedicated CW coupler
  Pin-on only
  Boom mount
  Not recommended

\*Offerings not available in all areas. Matches are dependent on machine configurations. Consult your Cat dealer to determine what is offered in your area and for proper work tool match.

Fixed CAN: CW quick coupler adapter plates

# MH3022 Wheel Material Handler Specifications

## MH3022 Work Tool Offering Guide with Drop Nose Sticks\*

		Boom Length	MH Boom (6.4 m)		MH Boom (5.35 m)	
		Counterweight	3700 kg	4200 kg	3700 kg	4200 kg
		Undercarriage/Outriggers	(1)	(1)	(1)	(1)
		Stick Length	4900 mm	4900 mm	4900 mm	4900 mm
		Stick Type	MH Stick (drop nose)		MH Stick (drop nose)	
Orange Peel Grapple (4 or 5 tines)	GSH15B 400 L					
	GSH15B 500 L					
	GSH15B 600 L					
	GSH15B 800 L					
	GSH20B 600 L					
	GSH20B 800 L					
	GSH20B 1000 L					
Orange Peel Grapple (5 tines)	GSM25 400 L					
	GSM25 500 L					
	GSM25 600 L					
	GSM25 800 L					
	GSM35 500 L					
	GSM35 600 L					
	GSM35 800 L					
	GSM35 1000 L					
Clamshell Grapple	CTV15 1000 L					
	CTV15 1200 L					
	CTV15 1500 L					
	CTV15 1700 L					
	CTV15 1900 L					

(1) MH undercarriage with 2 sets outriggers

 Maximum density 1.2 t/m<sup>3</sup> (light material)

 Maximum density 1.8 t/m<sup>3</sup> (standard material)

\*Offerings not available in all areas. Matches are dependent on machine configurations. Consult your Cat dealer to determine what is offered in your area and for proper work tool match.





# MH3022 Wheel Material Handler Specifications

## Lift Capacities

All values are in kg, without work tool, with counterweight (4200 kg), heavy lift on.

 Load point height

 Load over front

 Load over rear

 Load over side

 Load at maximum reach (sticknose/bucket pin)

### Undercarriage















MH (2.99 m) or MH Narrow (2.55 m)

### Boom

5.35 m MH

### Stick

4.2 m Straight Stick

	Undercarriage configuration	3000 mm			4500 mm			6000 mm			7500 mm			9000 mm						mm
																				
9000 mm	SA – 2 sets stabilizers up				*8550	*8550	6950										*5750	*5750	4400	5900
	SA – 2 sets stabilizers down				*8550	*8550	*8550										*5750	*5750	*5750	
	Narrow – 2 sets stabilizers up				*8500	*8500	6200										5400	5400	3950	
	Narrow – 2 sets stabilizers down				*8500	*8500	*8500										*5800	*5800	*5800	
7500 mm	SA – 2 sets stabilizers up							5900	5900	4450							4150	4150	3050	7380
	SA – 2 sets stabilizers down							*8250	*8250	*8250							*5100	*5100	*5100	
	Narrow – 2 sets stabilizers up							5350	5350	3950							3750	3750	2700	
	Narrow – 2 sets stabilizers down							*8200	*8200	7150							*5100	*5100	5000	
6000 mm	SA – 2 sets stabilizers up							5900	5900	4400	4050	4050	3000				3350	3350	2450	8340
	SA – 2 sets stabilizers down							*8600	*8600	*8600	*7300	*7300	6450				*4800	*4800	*4800	
	Narrow – 2 sets stabilizers up							5350	5350	3900	3650	3650	2650				3050	3050	2150	
	Narrow – 2 sets stabilizers down							*8600	*8600	7100	6950	6950	4900				*4800	*4800	4050	
4500 mm	SA – 2 sets stabilizers up				9200	9200	6750	5750	5750	4250	4000	4000	2950				2950	2950	2150	8940
	SA – 2 sets stabilizers down				*11 100	*11 100	*11 100	*8900	*8900	*8900	*7350	*7350	6400				*4750	*4750	*4750	
	Narrow – 2 sets stabilizers up				8300	8300	6000	5200	5200	3800	3600	3600	2600				2650	2650	1850	
	Narrow – 2 sets stabilizers down				*11 050	*11 050	*11 050	*8900	*8900	7000	6850	6850	4850				*4750	*4750	3600	
3000 mm	SA – 2 sets stabilizers up	17 750	17 750	12 050	8700	8700	6300	5500	5500	4050	3900	3900	2850	2900	2900	2100	2750	2750	2000	9260
	SA – 2 sets stabilizers down	*18 000	*18 000	*18 000	*12 250	*12 250	*12 250	*9300	*9300	9050	*7400	*7400	6250	*5750	*5750	4650	*4850	*4850	4450	
	Narrow – 2 sets stabilizers up	15 750	15 750	10 550	7850	7850	5600	4950	4950	3600	3500	3500	2500	2600	2600	1800	2450	2450	1700	
	Narrow – 2 sets stabilizers down	*17 950	*17 950	*17 950	*12 200	*12 200	10 900	*9300	*9300	6750	6750	6750	4700	5000	5000	3500	4800	4800	3350	
1500 mm	SA – 2 sets stabilizers up	*11 900	*11 900	10 650	8150	8150	5850	5250	5250	3850	3750	3750	2750	2850	2850	2050	2700	2700	1950	9320
	SA – 2 sets stabilizers down	*11 900	*11 900	*11 900	*12 950	*12 950	*12 950	*9450	*9450	8750	*7250	*7250	6150	*5300	*5300	4600	*4750	*4750	4400	
	Narrow – 2 sets stabilizers up	*12 350	*12 350	9200	7300	7300	5100	4750	4750	3350	3350	3350	2400	2550	2550	1750	2400	2400	1650	
	Narrow – 2 sets stabilizers down	*12 350	*12 350	*12 350	*12 950	*12 950	10 300	*9450	*9450	6450	6600	6600	4600	4950	4950	3450	4700	4700	3300	
0 mm	SA – 2 sets stabilizers up	*6250	*6250	*6250	7750	7750	5450	5050	5050	3650	3650	3650	2650							
	SA – 2 sets stabilizers down	*6250	*6250	*6250	*12 250	*12 250	*12 250	*8900	*8900	8500	*6600	*6600	6000							
	Narrow – 2 sets stabilizers up	*6250	*6250	*6250	6900	6900	4750	4550	4550	3150	3250	3250	2300							
	Narrow – 2 sets stabilizers down	*6250	*6250	*6250	*12 300	*12 300	9850	*8900	*8900	6250	6500	6500	4500							
-1500 mm	SA – 2 sets stabilizers up				7600	7600	5300	4950	4950	3550										
	SA – 2 sets stabilizers down				*9850	*9850	*9850	*7300	*7300	*7300										
	Narrow – 2 sets stabilizers up				6700	6700	4550	4400	4400	3050										
	Narrow – 2 sets stabilizers down				*9950	*9950	9650	*7350	*7350	6150										

\*Limited by hydraulic rather than tipping load.

Lift capacity ratings are based on ISO 10567:2007, they do not exceed 87% of hydraulic lifting capacity or 75% of tipping load. The load point is the center line of the bucket pivot mounting pin on the stick. The oscillating axle must be locked. Lifting capacities are based on the machine standing on a firm uniform supporting surface. For lifting capacity including bucket and/or quick coupler, the respective weight has to be subtracted from above values. The use of a work tool attachment point to handle/lift objects, could affect the machine lift performance.

Always refer to the appropriate Operation and Maintenance Manual for specific product information.

# MH3022 Wheel Material Handler Specifications

## Lift Capacities

All values are in kg, without work tool, with counterweight (4200 kg), heavy lift on.



### Undercarriage

MH (2.99 m) or MH Narrow (2.55 m)

### Boom

6.4 m MH

### Stick

4.9 m MH

Load point height	Undercarriage configuration	3000 mm			4500 mm			6000 mm			7500 mm			9000 mm			10 500 mm			mm			
		Load over front	Load over rear	Load over side	Load over front	Load over rear	Load over side	Load over front	Load over rear	Load over side	Load over front	Load over rear	Load over side	Load over front	Load over rear	Load over side	Load over front	Load over rear	Load over side	Load over front	Load over rear	Load over side	
10 500 mm	SA – 2 sets stabilizers up							6250	6250	4750											5200	5200	3950
	SA – 2 sets stabilizers down							*6500	*6500	*6500											*5250	*5250	*5250
	Narrow – 2 sets stabilizers up							5650	5650	4250											4750	4750	3550
	Narrow – 2 sets stabilizers down							*6450	*6450	*6450											*5300	*5300	*5300
9000 mm	SA – 2 sets stabilizers up							6350	6350	4850	4450	4450	3400								3700	3700	2800
	SA – 2 sets stabilizers down							*7850	*7850	*7850	*6300	*6300	*6300								*4700	*4700	*4700
	Narrow – 2 sets stabilizers up							5800	5800	4350	4050	4050	3000								3400	3400	2500
	Narrow – 2 sets stabilizers down							*7850	*7850	7600	*6250	*6250	5300								*4700	*4700	4450
7500 mm	SA – 2 sets stabilizers up							6350	6350	4850	4450	4450	3400	3300	3300	2500					3050	3050	2300
	SA – 2 sets stabilizers down							*8200	*8200	*8200	*7100	*7100	6900	*5500	*5500	5100					*4400	*4400	*4400
	Narrow – 2 sets stabilizers up							5800	5800	4350	4050	4050	3050	3000	3000	2200					2750	2750	2050
	Narrow – 2 sets stabilizers down							*8150	*8150	7600	*7100	*7100	5300	5450	5450	3950					*4400	*4400	3650
6000 mm	SA – 2 sets stabilizers up							6250	6250	4750	4400	4400	3350	3300	3300	2500					2700	2700	2000
	SA – 2 sets stabilizers down							*8400	*8400	*8400	*7200	*7200	6800	*6200	*6200	5100					*4300	*4300	4150
	Narrow – 2 sets stabilizers up							5700	5700	4250	4000	4000	3000	3000	3000	2200					2400	2400	1750
	Narrow – 2 sets stabilizers down							*8400	*8400	7500	*7200	*7200	5250	5450	5450	3900					*4300	*4300	3200
4500 mm	SA – 2 sets stabilizers up				9450	9450	7000	6000	6000	4550	4300	4300	3250	3250	3250	2450	2500	2500	1850	2450	2450	1800	
	SA – 2 sets stabilizers down				*11 150	*11 150	*11 150	*8900	*8900	*8900	*7350	*7350	6700	6200	6200	5000	4850	4850	3950	*4300	*4300	3850	
	Narrow – 2 sets stabilizers up				8550	8550	6250	5450	5450	4050	3900	3900	2850	2900	2150	2250	2250	1650	2200	2200	1600		
	Narrow – 2 sets stabilizers down				*11 150	*11 150	*11 150	*8850	*8850	7250	7150	7150	5100	5350	5350	3850	4200	4200	3000	4100	4100	2950	
3000 mm	SA – 2 sets stabilizers up	17 550	17 550	11 900	8800	8800	6450	5700	5700	4250	4100	4100	3100	3150	3150	2350	2500	2500	1850	2350	2350	1700	
	SA – 2 sets stabilizers down	*18 550	*18 550	*18 550	*12 350	*12 350	*12 350	*9350	*9350	9250	*7550	*7550	6500	6050	6050	4950	4800	4800	3900	*4400	*4400	3650	
	Narrow – 2 sets stabilizers up	15 550	15 550	10 400	7950	7950	5700	5150	5150	3750	3700	3700	2700	2850	2850	2050	2250	2250	1600	2100	2100	1500	
	Narrow – 2 sets stabilizers down	*18 500	*18 500	*18 500	*12 350	*12 350	11 000	*9350	*9350	6950	7000	7000	4950	5250	5250	3750	4150	4150	3000	3900	3900	2800	
1500 mm	SA – 2 sets stabilizers up				8150	8150	5850	5400	5400	3950	3950	3950	2900	3050	3050	2250	2450	2450	1800	2300	2300	1650	
	SA – 2 sets stabilizers down				*13 000	*13 000	*13 000	*9550	*9550	8850	*7500	*7500	6300	5950	5950	4800	*4700	*4700	3850	*4100	*4100	3600	
	Narrow – 2 sets stabilizers up				7300	7300	5100	4850	4850	3500	3550	3550	2550	2750	1950	2200	2200	1550	2050	2050	1450		
	Narrow – 2 sets stabilizers down				*13 000	*13 000	10 250	*9550	*9550	6600	6800	6800	4750	5150	5150	3650	4100	4100	2950	3850	3850	2750	
0 mm	SA – 2 sets stabilizers up	*3500	*3500	*3500	7700	7700	5400	5150	5150	3700	3800	3800	2800	2950	2950	2150	2400	2400	1750				
	SA – 2 sets stabilizers down	*3500	*3500	*3500	*12 200	*12 200	*12 200	*9150	*9150	8600	*7150	*7150	6150	*5550	*5550	4750	*4050	*4050	3800				
	Narrow – 2 sets stabilizers up	*3500	*3500	*3500	6850	6850	4700	4600	4600	3250	3400	3400	2400	2650	2650	1900	2150	2150	1500				
	Narrow – 2 sets stabilizers down	*3500	*3500	*3500	*12 350	*12 350	9750	*9200	*9200	6300	6600	6600	4600	5050	5050	3600	*4050	*4050	2900				
-1500 mm	SA – 2 sets stabilizers up				7450	7450	5200	5000	5000	3600	3700	3700	2700	2900	2900	2100							
	SA – 2 sets stabilizers down				*9600	*9600	*9600	*8000	*8000	*8000	*6200	*6200	6050	*4650	*4650	*4650							
	Narrow – 2 sets stabilizers up				6650	6650	4500	4450	4450	3100	3300	3300	2350	2600	2600	1850							
	Narrow – 2 sets stabilizers down				*9600	*9600	9500	*8000	*8000	6150	*6250	*6250	4500	*4700	*4700	3550							

\*Limited by hydraulic rather than tipping load.

Lift capacity ratings are based on ISO 10567:2007, they do not exceed 87% of hydraulic lifting capacity or 75% of tipping load. The load point is the center line of the bucket pivot mounting pin on the stick. The oscillating axle must be locked. Lifting capacities are based on the machine standing on a firm uniform supporting surface. For lifting capacity including bucket and/or quick coupler, the respective weight has to be subtracted from above values. The use of a work tool attachment point to handle/lift objects, could affect the machine lift performance.

Always refer to the appropriate Operation and Maintenance Manual for specific product information.





# MH3022 Wheel Material Handler Specifications

## Lift Capacities

All values are in kg, without work tool, with counterweight (4200 kg), heavy lift on.

 Load point height

 Load over front

 Load over rear

 Load over side

 Load at maximum reach (sticknose/bucket pin)

### Undercarriage















MH (2.99 m) or MH Narrow (2.55 m)

### Boom

6.4 m MH

### Stick

4.2 m Straight Stick

	Undercarriage configuration	3000 mm			4500 mm			6000 mm			7500 mm			9000 mm						mm
																				
9000 mm	SA – 2 sets stabilizers up							5900	5900	4400							4050	4050	3000	7420
	SA – 2 sets stabilizers down							*8100	*8100	*8100							*5300	*5300	*5300	
	Narrow – 2 sets stabilizers up							5350	5350	3900							3700	3700	2650	
	Narrow – 2 sets stabilizers down							*8050	*8050	7150							*5300	*5300	4950	
7500 mm	SA – 2 sets stabilizers up							5900	5900	4400	4050	4050	3000				3150	3150	2250	8640
	SA – 2 sets stabilizers down							*8250	*8250	*8250	*7000	*7000	6450				*4900	*4900	*4900	
	Narrow – 2 sets stabilizers up							5350	5350	3950	3650	3650	2650				2800	2800	2000	
	Narrow – 2 sets stabilizers down							*8250	*8250	7150	6950	6950	4900				*4900	*4900	3800	
6000 mm	SA – 2 sets stabilizers up				9350	9350	6900	5800	5800	4300	4000	4000	2950	2900	2900	2100	2650	2650	1900	9460
	SA – 2 sets stabilizers down				*10 600	*10 600	*10 600	*8500	*8500	*8500	*7050	*7050	6400	5850	5850	4700	*4750	*4750	4300	
	Narrow – 2 sets stabilizers up				8450	8450	6100	5250	5250	3800	3600	3600	2600	2600	2600	1800	2350	2350	1650	
	Narrow – 2 sets stabilizers down				*10 600	*10 600	*10 600	*8450	*8450	7050	6900	6900	4850	5050	5050	3550	4600	4600	3250	
4500 mm	SA – 2 sets stabilizers up	*14 500	*14 500	12 500	8850	8850	6450	5550	5550	4100	3900	3900	2850	2850	2850	2050	2350	2350	1650	10 000
	SA – 2 sets stabilizers down	*14 500	*14 500	*14 500	*11 500	*11 500	*11 500	*8850	*8850	*8850	*7150	*7150	6250	5800	5800	4650	*4750	*4750	3900	
	Narrow – 2 sets stabilizers up	*14 250	*14 250	10 950	8000	8000	5700	5000	5000	3600	3500	3500	2500	2550	2550	1750	2100	2100	1400	
	Narrow – 2 sets stabilizers down	*14 250	*14 250	*14 250	*11 500	*11 500	11 100	*8850	*8850	6800	6750	6750	4700	5000	5000	3500	4200	4200	2900	
3000 mm	SA – 2 sets stabilizers up				8200	8200	5850	5250	5250	3800	3700	3700	2700	2800	2800	2000	2200	2200	1550	10 280
	SA – 2 sets stabilizers down				*12 450	*12 450	*12 450	*9200	*9200	8750	*7200	*7200	6100	5700	5700	4550	*4500	*4500	3700	
	Narrow – 2 sets stabilizers up				7350	7350	5100	4700	4700	3350	3350	2350	2450	2450	1700	1950	1950	1300		
	Narrow – 2 sets stabilizers down				*12 400	*12 400	10 350	*9150	*9150	6450	6600	6600	4550	4900	4900	3400	3950	3950	2750	
1500 mm	SA – 2 sets stabilizers up				7550	7550	5300	4950	4950	3550	3550	3550	2550	2700	2700	1900	2150	2150	1500	10 340
	SA – 2 sets stabilizers down				*12 450	*12 450	*12 450	*9100	*9100	8400	*7000	*7000	5900	*5450	*5450	4450	*3950	*3950	3600	
	Narrow – 2 sets stabilizers up				6700	6700	4550	4400	4400	3050	3150	3150	2200	2400	2400	1600	1900	1900	1250	
	Narrow – 2 sets stabilizers down				*12 500	*12 500	9650	*9100	*9100	6150	6400	6400	4400	4800	4800	3300	3900	3900	2650	
0 mm	SA – 2 sets stabilizers up				7200	7200	4950	4750	4750	3350	3450	3450	2400	2650	2650	1850				
	SA – 2 sets stabilizers down				*9400	*9400	*9400	*8350	*8350	8150	*6400	*6400	5800	*4800	*4800	4400				
	Narrow – 2 sets stabilizers up				6350	6350	4250	4200	4200	2850	3050	3050	2050	2350	2350	1550				
	Narrow – 2 sets stabilizers down				*9450	*9450	9250	*8400	*8400	5900	6250	6250	4250	4750	4750	3250				

\*Limited by hydraulic rather than tipping load.

Lift capacity ratings are based on ISO 10567:2007, they do not exceed 87% of hydraulic lifting capacity or 75% of tipping load. The load point is the center line of the bucket pivot mounting pin on the stick. The oscillating axle must be locked. Lifting capacities are based on the machine standing on a firm uniform supporting surface. For lifting capacity including bucket and/or quick coupler, the respective weight has to be subtracted from above values. The use of a work tool attachment point to handle/lift objects, could affect the machine lift performance.

Always refer to the appropriate Operation and Maintenance Manual for specific product information.

## Standard Equipment

Standard equipment may vary. Consult your Cat dealer for details.

### ELECTRICAL

- Alternator, 115A
- Heavy Duty maintenance free batteries
- Lights
  - Boom and stick LED working light
  - One LED light on the counterweight
  - Cab LED interior dome light
  - Rooding lights two front
  - Rooding lights two rear
  - Working LED lights, cab mounted (front and rear)
- Main shut-off switch
- Signal/warning horn

### ENGINE

- Air filter
- Altitude capability: 3000 m
- Automatic engine speed control, including One Touch Low Idle
- Engine Idle Shutdown
- Automatic starting aid
- Cat C7.1 ACERT meeting Stage IV emission standards
- Fuel filter
- Fuel/water separator with level indicator
- High ambient cooling
- Power mode selector (economy, power)

### HYDRAULICS

- Adjustable hydraulic sensitivity
- Cat XT™-6 ES hoses
- Control circuits (standard and optional, depending on boom/stick/linkage choice):
  - Medium pressure
    - Two-way, medium pressure circuit, for rotating or tilting of work tools
- Heavy lift mode
- Load-sensing hydraulic system
- Oil cooler
- Quick disconnect couplings
- Separate swing pump

### OPERATOR STATION

- Additional color monitor for sideview camera
- Adjustable armrests
- Air conditioner, heater and defroster with automatic climate control
- Beverage cup/can holder
- Bolt-on top/front guards capability
- Bottle holder
- Bottom mounted, intermittent, parallel wiping system, covering upper and lower windshield glass
- Camera integrated into the counterweight displays through cab monitor
- CD/MP3 radio (12V) at rear location including speakers and 12V converter
- Coat hook
- Cruise control system
- Floor mat, washable, with storage compartment
- Fully adjustable suspension seat
- Hydraulic cab riser
- Instrument panel and gauges, full graphic and color display
  - Information and warning messages in local language
  - Gauges for fuel and DEF levels, engine coolant and hydraulic oil temperature
  - Filters/fluids change interval, working hours
  - Indicators for headlights, turning signal, low fuel and DEF, engine dial setting
  - Clock with 10-day backup battery
- Interior lighting with door switch
- Joysticks, pilot operated
- Laminated front windshield
- Left side console, tiltable, with lock out for all controls
- Lighter (24V)
- Literature compartment behind seat
- Literature holder in right console
- Mobile phone holder
- Parking brake
- Pin code type engine start prevention, integrated into the monitor
- Positive filtered ventilation, variable speed
- Power supply, 12V-10A

- Rear window, emergency exit
- Retractable seat belt, integrated into the seat
- Seat belt indicator and alarm
- Skylight
- Sliding door windows
- Steering column, adjustable angle and height
- Step, integrated into the skirt
- Storage area suitable for a lunch box
- Sunshade for windshield and skylight

### UNDERCARRIAGE

- Automatic brake and axle lock
- Automatic swing and implement lock
- Creeper speed
- Four wheel drive
- Full hydraulic steering with emergency capability
- Heavy-duty axles, advanced travel motor, adjustable braking force and disc brake system
- Oscillating front axle, lockable, with remote greasing
- Steps, wide, left and right
- Tool boxes, left and right, in undercarriage
- Two-speed hydrostatic transmission
- Cooling package, fine mesh screen, with engine air precleaner

### OTHER EQUIPMENT

- Auto-lube system (implements and swing gear)
- Automatic swing brake
- Capability to add auxiliary hydraulic circuit
- Electronic Technician capability (ET)
- Counterweight, 3700 kg
- Door locks and cap locks with Cat one-key security system
- Lowering check valves, BLCV including overload warning device and SLCV
- Mirrors, frame and cab
- Product Link
- Rear wide angle camera
- Side wide angle camera
- S·O·S<sup>SM</sup> Quick Sampling valves for engine oil, hydraulic oil and coolant



## Optional Equipment

Optional equipment may vary. Consult your Cat dealer for details.

### AUXILIARY CONTROLS AND LINES

- Auxiliary boom and stick lines
- Control circuits (standard and optional, depending on boom/stick/linkage choice):
  - Tool control/multi function
    - One/two-way high pressure for hammer application or opening and closing of a work tool
    - Programmable flow and pressure for up to 10 work tools – selection via monitor
  - Quick coupler control
- Cat BIO HYDO Advanced HEES™ biodegradable hydraulic oil
- SmartBoom

### BOOMS AND STICKS

- VA boom (5260 mm):
  - Straight stick (2500, 2800 mm)
  - Industrial stick (3300 mm)
- One-Piece boom (5350 mm):
  - Straight stick (2500, 2800 mm)
  - Industrial stick (3300 mm)
- Material Handling boom (6400 mm):
  - Drop nose MH stick (4900 mm)
  - Straight MH stick (4200 mm)
- Material Handling boom (5350 mm):
  - Drop nose MH stick (4900 mm)
  - Straight MH stick (4200 mm)

### ELECTRICAL

- Back-up alarm with three selectable modes
- Rotating beacon

### OPERATOR STATION

- Top/front guards
- Joystick steering
- Pedal HPF/Hammer for auxiliary operation
- Seat, adjustable high-back
  - Vertical air suspension, horizontal suspension, automatic weight adjustment, lumbar support, passive climate system, seat cushion length/angle adjustment and heated seat (Comfort)
  - Vertical air suspension, horizontal suspension, automatic height and weight adjustment, active climate system, premium microfiber seat fabric, pneumatic lumbar support, seat cushion length and angle adjustment and adjustable dampening (Deluxe)
- Visor for rain protection
- Windshield
  - One-piece fixed
  - 70/30 split, openable

### TIRES\*

- Dual pneumatic 10.00-20
- Dual pneumatic 11.00-20
- Dual solid rubber, 10.00-20
- Spacer rings for tires

### UNDERCARRIAGE

- MH Narrow undercarriage with four welded outriggers
- MH undercarriage with four welded outriggers
- MH undercarriage with four welded outriggers and front mounted blade
- Standard undercarriage, with outriggers (front and/or rear), dozer blade (front or rear)

### OTHER EQUIPMENT

- Bucket linkages
- Cat Machine Security System
- Counterweight, 4200 kg
- Hydraulic quick coupler
- Maximum speed 20 km/h or 25 km/h\*\*
- Mirrors heated, frame and cab
- Refueling pump with dedicated tray for the hose

\*Dual Pneumatic 10.00-20 not compatible with MH undercarriage

Dual Pneumatic 11.00-20 not compatible with MH narrow undercarriage

\*\*25 km/h not compatible with solid tires

For more complete information on Cat products, dealer services, and industry solutions, visit us on the web at [www.cat.com](http://www.cat.com)

AEHQ7406-01 (08-2015)  
Replaces AEHQ7406

© 2015 Caterpillar  
All rights reserved

Materials and specifications are subject to change without notice. Featured machines in photos may include additional equipment. See your Cat dealer for available options.

CAT, CATERPILLAR, SAFETY.CAT.COM, their respective logos, "Caterpillar Yellow" and the "Power Edge" trade dress, as well as corporate and product identity used herein, are trademarks of Caterpillar and may not be used without permission.

VisionLink is a trademark of Trimble Navigation Limited, registered in the United States and in other countries.

